



SOTERA

SYSTEMS



The most versatile and robust Chemical Transfer System that you will ever own.

In today's agricultural and industrial markets, isn't it good to know that you can rely on one name to fit all your chemical transfer needs? The Sotera 400B Series offers proven technology which combines the attributes of an Air Operated Diaphragm pump, but the convenience and efficiency of an electromechanically driven design. It also uses less power than other conventional Chemical pumps for maximized efficiency.

One Way Valve Feature

Standard product inherently conforms to the EPA's 2011 mandate requiring package designs to not allow back filling of tote or drum.

Unique Design

Improves fluid handling capabilities with low material shear, solids handling up to (1/10"), viscosity range 0 - 3000 C.P.S., dry run capability and no internal bypass.

Heavy Duty Rugged Construction

Glass reinforced Polypropylene pump body provides integrity and excellent material compatability inside and out. It's the heart of our complete range of ready to use transfer systems.

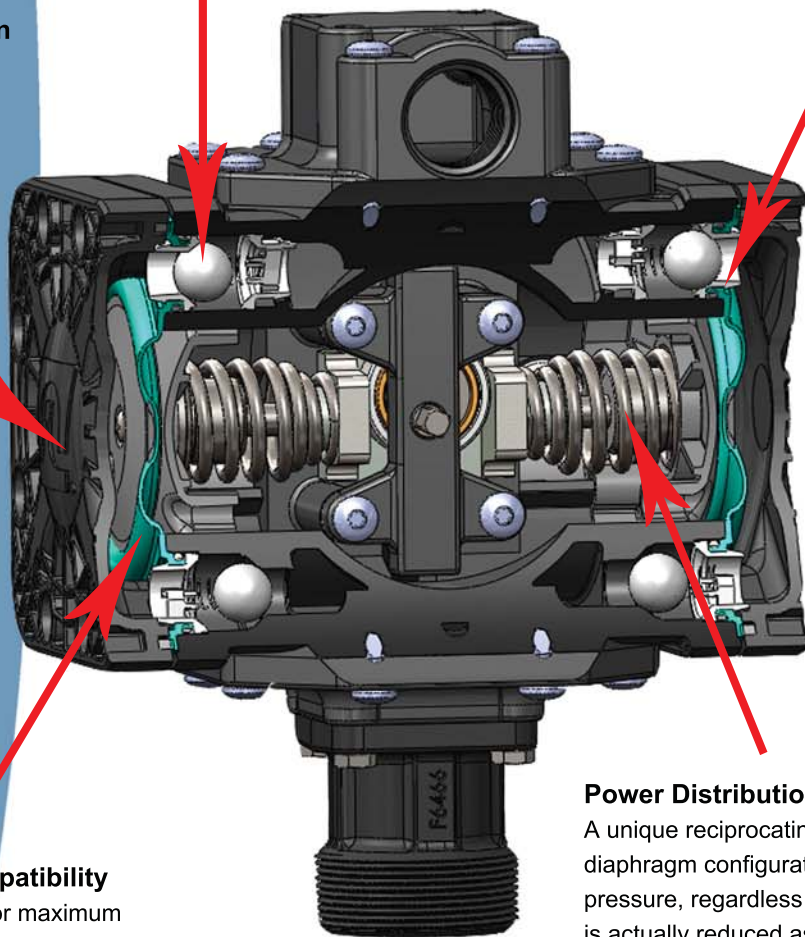

Optimized Fluid Compatibility

Santoprene diaphragm for maximum chemical and corrosion resistance.

Power Distribution

A unique reciprocating, spring driven double diaphragm configuration retains constant pressure, regardless of load. Motor amperage is actually reduced as back pressure increases. No internal bypass - pump automatically goes neutral when end of hose valve is shut off.

Series 400B Dual Diaphragm Chemical Pump Specifications

Pump Specifications

Reciprocating, spring-driven dual-diaphragm design

Flow Rate / Water: 15 GPM (1.5 cps)
12 GPM (350 cps)

Max Pressure: 15 psi

Max Lift / Water: 10'

Max Operating Temperature: 130 F

Materials of Construction

Pump: glass filled polypropylene

Internal wetted parts: polypropylene, fluorocarbon, stainless steel, EPDM or Fluorocarbon and Santoprene

Inlet port: 1" NPT, female

Outlet port: 1" NPT, female

Particle tolerance up to 0.1" diameter

Motor Specifications

115V AC, 12V DC, 24V DC

1/4 Hp, 12 amps maximum draw (12V DC) with 20' DC cable, alligator clips and a 30 amp fuse

1/4 Hp, 1.2 amps maximum draw (115V AC) with a heavy-duty 3 wire cable and plug

Thermal overload protection

Quality ball bearing motor construction

Model SS435B Chemtraveller

Portable pump on tubular frame complete with top and bottom adapter kits.

Included but not shown is a 9' EPDM inlet Ag hose, 12' EPDM outlet Ag hose, 825 meter, shut off ball valve with non-drip nozzle ball valve and all connection fittings.



Model SS445B

Integral Liquid recirculation pump for chemicals that stratify or separate. Diaphragms reduce risk of shearing, ensuring safe mixing without breakdown. There is no need for external valving. Mounts on 9" GEM threads.

Included but not shown is a telescoping Polypropylene suction tube, 12' EPDM Ag hose, 825 meter, shut off ball valve and connection fittings.



Model SS417B

Quickly attaches to generic 2" NPT or butress tank (barrel) openings.

Included but not shown is a telescoping Polypropylene suction tube, 12' EPDM outlet Ag hose, all connection fittings and shut off ball valve.



Model SS419BX665

Side tank mount system that attaches to IBC.

Included but not shown is a 12' EPDM outlet Ag hose, fittings and shut off ball valve.



Model SS420B

Tank and drum mounted system used on most 2" NPT applications.

Included but not shown is a telescoping Polypropylene suction tube, 12' EPDM outlet Ag hose, shut off ball valve and nozzle retainer.



Model SS415BX731PG

Especially suited to economically pull liquid from the top (2" NPT) or bottom (2" Camlok) of caged IBC's and drums.

Included but not shown is a telescoping Polypropylene suction tube, 12' outlet EPDM Ag hose, 3' EPDM inlet Ag hose, shut off ball valve, Stainless Steel floor stand and all connection fittings.



Series 820 Digital Meter

Meter Specifications

Flow Rate:	2 to 20 GPM (7.6 to 75.7 liters)
Max Pressure:	120 psi (8.2 bars)
Flow Ports:	Two 1" NPT inlet / outlet ports femal threads
Accuracy:	+/- 0.5% using calibration factor +/- 0.2% using liquid calibration
Calibration:	Ounces, pints, quarts, liters, gallons, special units
Totalizer Range:	9999 current total; 10,000,000 accumulated total

Materials of Construction

Body:	Glass-filled polypropylene
Chamber:	Ryton, 302 Stainless Steel
Display:	LCD (Liquid Crystal Display)
Power Source:	Two alkaline AA batteries (included)
Dimensions:	5.5" x 3.25" x 5"

Model 825



Used at the end of a hose, in-line system or mounted to a Sotera Series 400B chemical transfer pump.

Model 850



Same great features as the Model 825 with added mass air sensing. Meter will stop counting when fluid is not present (tote runs dry).